

CAUTION !! All new procedures and processes should be checked in the 'Test' environment before being applied to the 'Live' business system.

WORKS ORDERS –STATUSES & PARAMETERS

Example assembly CA1700 Pump Assembly (MFR)
|
CA1750 Pump Kit (Purchased, Qty = 1)

In the example below assume that a works order is placed for 1 off CA1700

STATUSES

- | | | |
|----|---------------------|---------------------------------------------|
| 0 | Direct Entry | Make to Stock |
| 1 | From Sales Order | Make to Order - takes the S/O line quantity |
| 5 | (Materials) Issued | |
| 8 | Completed/Closed | |
| 9 | Marked for Archive | |
| 10 | Marked for Deletion | |

'On Hold' orders have statuses from 100 upwards, depending on their status at the point at which they were placed on hold. For example,

- | | |
|-----|---------------------------------------|
| 100 | On Hold, from Direct Entry W/O |
| 101 | On Hold, from Sales Order entered W/O |
| 105 | On Hold, from Issued W/O |

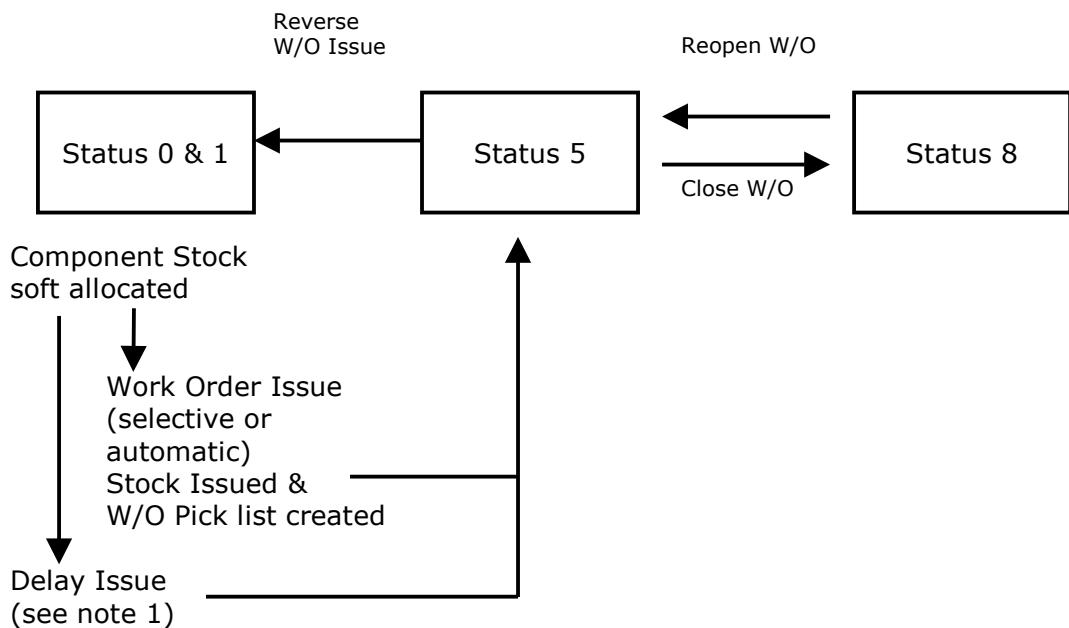

Note 1

Delay Issue moves status on to 5, but no stock is actually issued. The shortage is changed from Projected Shortage PS to Firm Shortage FS. For use when there is no component stock currently available. Adds a note to the subsequent component GRN when goods received that the item is awaited on the Works Order.

Note 2

The functions 'Hold/Release Hold' moves status to +100 and returns to the original status

On hold orders do not appear on the Projected Reorder reports

STOCK VIEWS

Stock Records (At status 0 or 1 for component CA1750)

Stock Card	Supply/Demand	Stock Status
8 Available	8 Available 1 Allocated (Projected Shortage PS) Soft Allocation	7 Soft Free Stock 8 Hard Free Stock

Stock Records (At status 5 for component CA1750 – following Works Order Issue)

Stock Card	Supply/Demand	Stock Status
7 Available	No Supply/Demand	7 Soft Free Stock 7 Hard Free Stock

Stock Records (At status 5 for component CA1750 – following Works Order Delay Issue)

Stock Card	Supply/Demand	Stock Status
8 Available	8 Available 1 Allocated (Firm Shortage FS)	7 Soft Free Stock 8 Hard Free Stock

BlueStone Solutions for Business

Unit A, Tayside Software Centre, Technology Park, Dundee, DD2 1TY

Email: sales@bluestone-solutions.co.uk www.bluestone-solutions.co.uk

Offices in Leicester & Bristol. For all locations contact (0800) 027 3775

PARAMETERS

Note that there is an option within SOP parameters to Auto Create Works Orders for Sales Order lines in a Make-to-Order situation. There is a further option to create sub-assembly works orders

BlueStone Solutions for Business

Unit A, Tayside Software Centre, Technology Park, Dundee, DD2 1TY

Email: sales@bluestone-solutions.co.uk www.bluestone-solutions.co.uk

Offices in Leicester & Bristol. For all locations contact (0800) 027 3775